



compac

INTEGRATED REFUELLING SOLUTIONS

Installation and Setup Instructions

Model: Master
Version: MR400S Aviation
Serial No: 09A-12933901

Date of issue: 4 February, 2009

Compac Industries Ltd
P O Box 12-417
Penrose
Auckland
New Zealand
Ph 64 9 5792 094
Fax 64 9 5790 635
www.compac.co.nz

1.	Footprint	3
2.	Static Electricity Precautions.....	4
3.	Pre-installation Check	4
4.	Comms Dip-switch settings.....	4
4.1	Standard Pump Comms Setting	4
4.2	Gilbarco Pump comms Setting	4
5.	Triac Dip-switches	4
6.	Electrical Connections	5
6.1	Submersible Pump connection	5
7.	Setting up the C4000	6
7.1	Configuration Codes	6
7.2	Submersible Delay (Sd).....	6
7.3	Preset Cutoff (Pcut)	6
7.4	Parameter Switch settings	7
7.5	K-Factor Switch Settings	8
8.	Calibration (K-Factor).....	9
8.1	Setting the K-Factor.....	9
8.2	Sealing the K-Factor switch.....	9
8.3	Standalone Operation.....	10
9.	Spare Fuses.....	10
11.	Error Messages.....	11
12.	MR400S Spare Parts	12

1. Footprint

C4000 Junction Box.
Bring cables into here.

Contractor to supply
and install pipework
to connect to this
2" BSP Female connection

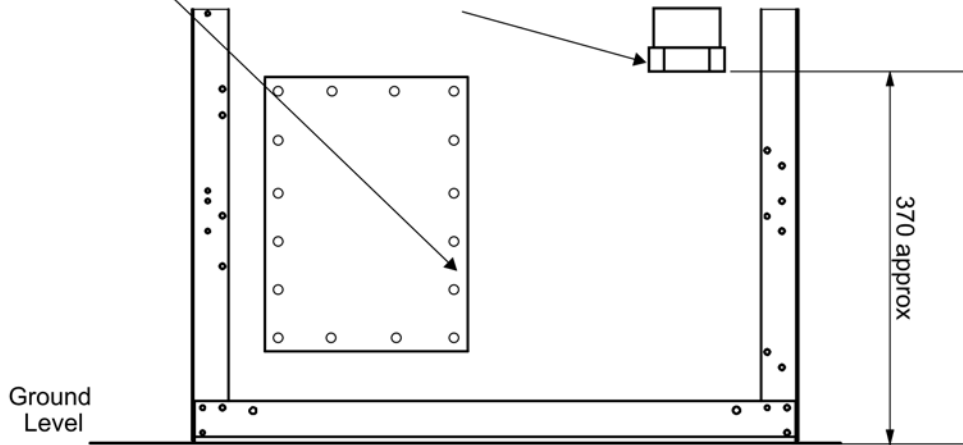

Front View

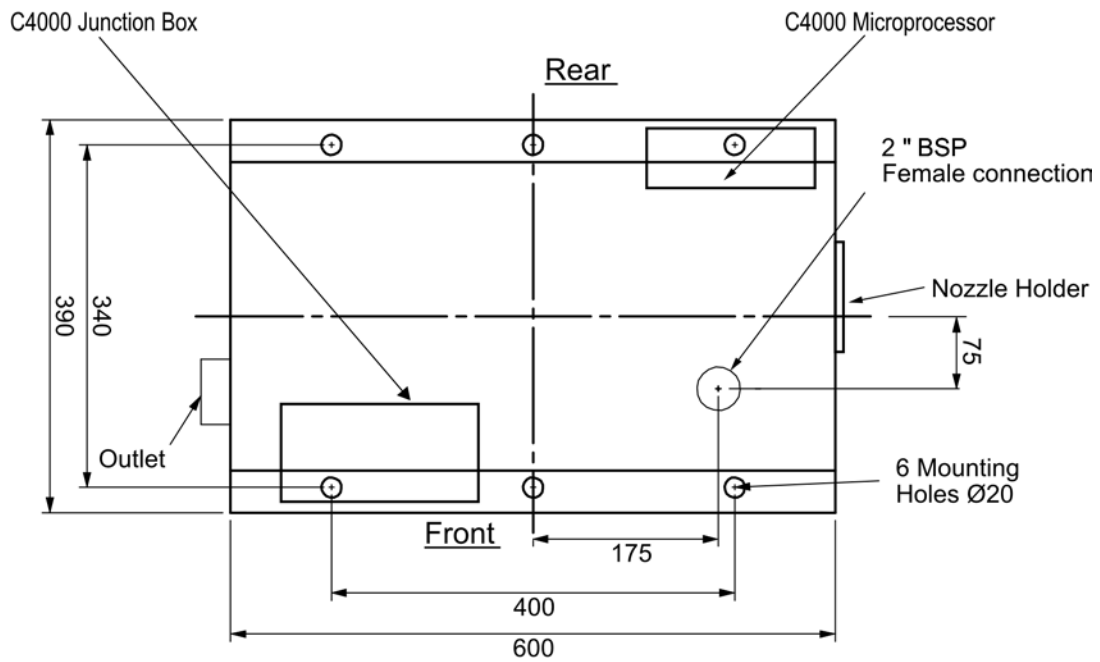

Footprint Plan View
MR400S AVIATION

2. Static Electricity Precautions

Electronic components used are sensitive to static. Please take anti-static precautions.

An anti-static wrist strap should be worn and connected correctly when working on any electronic equipment. If an anti-static wrist strap is unavailable, or in an emergency, hold onto an earthed part of the pump/dispenser frame whilst working on the equipment. This is not a recommended alternative to wearing an anti-static wrist strap.

Note: **Compac Industries Limited reserves the right to refuse to accept any circuit boards returned, if proper anti-static precautions have not been taken.**

3. Pre-installation Check

Once the pump is received on site, check that no damage has occurred while in transit – in particular, damage to electronics due to vibration or jarring. All terminals and plugs should be checked, including IC chips, to ensure they are securely in place.

4. Comms Dip-switch settings

4.1 Standard Pump Comms Setting

(Dipswitch SW3)

1-ON

2-OFF

3-ON

4-OFF

These are factory set to the standard setting unless ordered otherwise.eg Gilbarco.

4.2 Gilbarco Pump comms Setting

(Special software and interface board required)

1-OFF

2-ON

3-OFF

4-ON

5. Triac Dip-switches

Important note:

Great care should be taken not to accidentally change the setting of these switches while working in the Flame-proof box. Operating the unit with these incorrectly set can result in damage to the C4000 Power Supply or incorrect operation of the solenoid.

These switches are set in the factory and should not be changed.

If they are accidentally changed these are the correct settings for Master Dispenser applications. Note: They are 3 position switches

	Dispenser (low current output)
SW1	2
SW2	2
SW4	2

6. Electrical Connections

Prior to pump installation ensure that there is at least a two-metre tail on both the incoming underground 230 volt cable and Comms cable. These cables are terminated at the C4000 Power Supply, which is housed in the Flameproof Enclosure located in the bottom of the pump, behind the Door
The incoming cables are terminated as shown in the following picture.

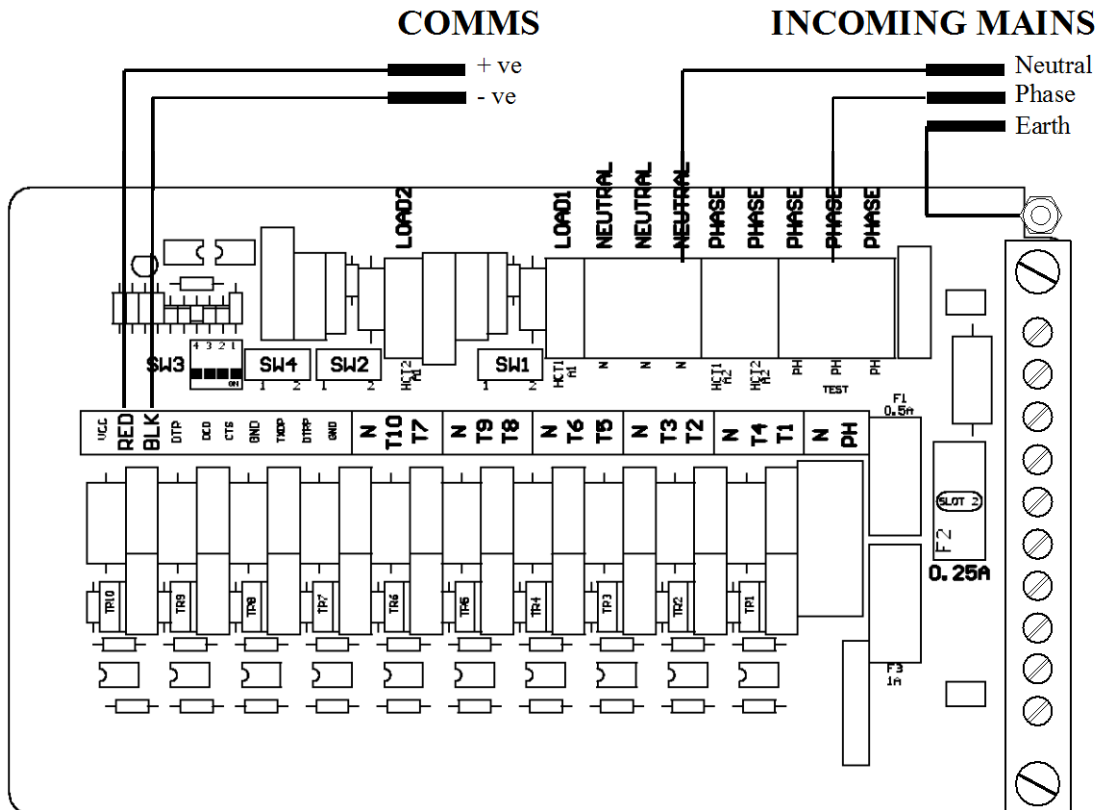

6.1 Submersible Pump connection

Single Dispensers

Connect the feed to the Submersible Pump Relay / Contactor to the terminal marked T1 on the C4000 Power Supply

Note: The terminals marked LOAD 1 & 2 are not used in Dispenser applications

7. Setting up the C4000

Once the pump is connected on site, the final setup check and calibration to complete the installation must be carried out, using the Parameter Switch and Calibration (K-Factor) Switch.

These switches are found on the C4000 Microprocessor Board which is housed in a metal enclosure located on the left front of the unit below the display panel. The Submersible delay and Pcut (Preset Cutoff) both may need to be adjusted on site as follows. These are found on the K factor switch.

7.1 Configuration Codes

The configuration code has been set at Compac and should not be changed. In the event of it being lost and having to be re-entered the configuration is written on the yellow label on the C4000 processor board cover.

Note: A special configuration code (07071) is required so that the preset amount is in litres instead of dollars.

7.2 Submersible Delay (Sd)

This is the time delay from when the Submersible pump starts to when the solenoids in the dispenser open to allow time for the leak detector to reset.

This is factory set by Compac at 005 (five seconds).

If problems are experienced with the leak detector tripping, firstly check that 'Sd' is still set and then, if necessary, make it longer as follows.

1. Press and release the K factor switch repeatedly until 'Sd' appears on the Dollar display. 'dXXX' will appear in the litres display.
2. Continue to press the K factor switch until the number to be changed flashes. Hold the switch down and this number will then increment.
3. Release the switch when the required number is displayed. The value of the displayed number will then be stored in the C4000 memory as the Submersible delay.

7.3 Preset Cutoff (Pcut)

If a preset keypad is fitted, it may be necessary to adjust the Pcut setting on site if the preset overruns. The Pcut setting turns the solenoid output (T3) off prior to the preset amount being reached to allow for preset overruns.

1. Do a preset delivery and observe if the preset overruns, and if so, by how much.
2. Press and release the K factor switch repeatedly until 'Pcut' appears on the Dollar display.
3. Increase the Pcut setting and do another delivery. Adjust the Pcut setting again if required. (The maximum value that the Pcut can be set to is 9.99 litres).

Notes:

1. The factory default setting is 0.00. When the Pcut is set to 0.00, the solenoid output (T3) turns off 0.5 litre before the preset amount, otherwise it turns off at the Pcut setting.
2. It may not be possible to make the Pcut amount large enough to eliminate any preset overruns completely.

7.4 Parameter Switch settings

7.4.1 Setting the Pump Number

This must be set at the pump, for each hose, so that communications with a controller can take place. The location of this switch is shown in the diagram below.

Depress the Parameter Switch nine (9) or more times until the message '**PnA XX**' appears in the litres display window. When the switch is pressed again '**Pnb XX**' will appear on the display. These two options will toggle each time the switch is pressed. To alter either of the pump numbers, press and hold the Parameter Switch when the pump number to be altered appears on the display. This number will then increment. The switch should be released when the desired pump number is displayed. The value of the displayed number will then be stored in the C4000 memory as the pump number for that hose.

NOTE: For a single hose only '**Pn**' will appear

7.4.2 Setting the Price

Using the Parameter Switch, follow the chart to set the price for the hose(s) in question.

Step	ACTION	RESULT
1	Ensure that the nozzle is hung up	Dispenser in idle state
2	Press and Hold the Parameter switch until the "Price per litre" is displayed.	The price for side 'A' is shown as 'PX.XXX' on the litres display and 'PrA' is displayed on the money display.
3	Press and hold the Parameter switch.	A digit, of the displayed 'Price per litre', will begin to increment.
4	When the digit is correct, release the Parameter switch.	
5	Repeat steps 3 and 4 for each digit of the 'Price per litre'.	NOTE: the C4000 will reset itself if the Parameter switch is left for more than 60 seconds.
Continue for Dual hose units		
6	Press and release the Parameter switch 8 or more times in quick succession	The price for side 'B' is shown as 'PX.XXX' on the litres display and 'Prb' is displayed on the money display.
7	Repeat steps 3 to 5 above.	

7.5 K-Factor Switch Settings

K-Factor, and other various configuration settings, are set via this switch. The position of the K-Factor switch is shown in the diagram below:

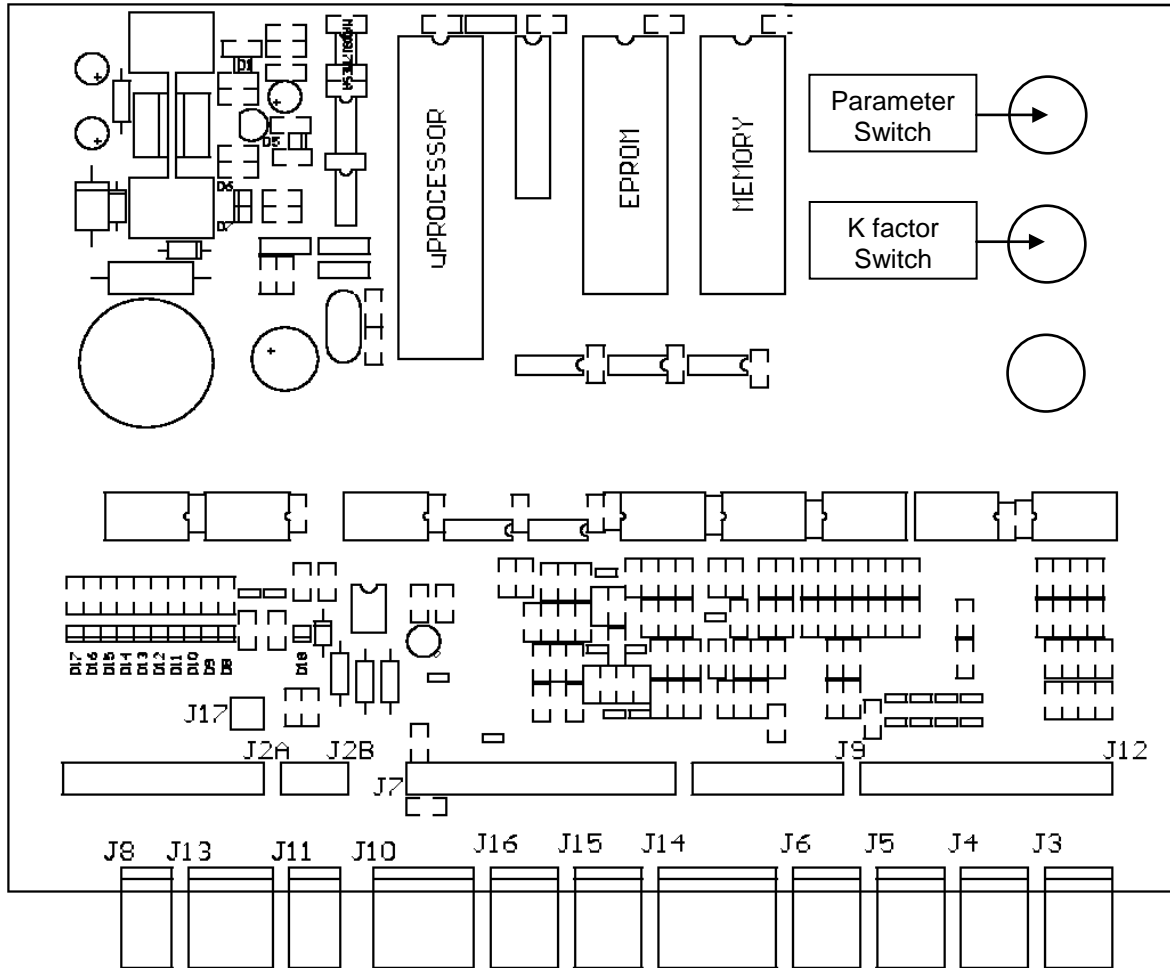

J1: Comms Test	J7: Displays	J13: Not used
J2: To Power Supply	J8: Temperature (for Temperature compensation only)	J14: Not used
J3 : Input from KG Meter Side A	J 9 Power for KG Meters	J15: Not used
J4: Input from KG Meter Side B	J10: Totes	J16: Not used
J5 : Not Used	J11: Buzzer	J17 Backlighting
J6 Not used	J12 Nozzle Switches	

8. Calibration (K-Factor)

8.1 Setting the K-Factor

K-Factor is a proportional calibration factor of litres dispensed per revolution of the meter.

To calibrate the dispenser/pump, dispense fuel into a certified measuring container, and compare the display value with the amount dispensed.

Example:

Display shows 10.00

True volume 20.00

To calculate the correct 'K' Factor from the information above; firstly record the existing 'K' Factor.

$$\begin{aligned}\text{New 'K' Factor} &= \text{Existing 'K' Factor} \times \frac{\text{Dispensed Amount}}{\text{Displayed Amount}} \\ &= \text{Existing 'K' Factor} \times \frac{20.00}{10.00} \\ &= \text{Existing 'K' Factor} \times 2\end{aligned}$$

Change the existing 'K' Factor to this new value.

8.2 Sealing the K-Factor switch

After calibration the K-factor switch should be sealed as shown

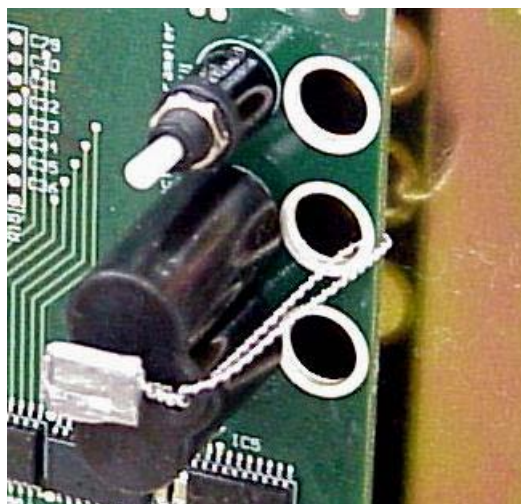

8.3 Standalone Operation

In standalone operation, the dispenser will continue working when not connected to a controller. *'Stand-alone'* mode being when no authorisation of fills is required and so fills are simply initiated by removing the refuelling assembly from its holder. If standalone operation is inhibited, the dispenser will not work in *'stand-alone'* mode, regardless of whether the dispenser is *ON LINE* to a controller or not.

The dispenser ceases to work in *'stand-alone'* mode if connected to a controller, regardless of the position of standalone setting.

Generally on retail forecourts the dispenser should be set-up for standalone operation. Hence, if the forecourt controller breaks down the dispensers can be set to work in *'stand-alone'* mode simply by turning them off then on again.

For unattended refuelling sites, the dispensers should not be able to work in *'stand-alone'* mode in the event of a controller failure. Therefore the dispenser should be set-up to inhibit standalone operation.

This is set in the 'b' code on the K factor switch.

The 'b' code to run Standalone without Dispenser Controller is '0000'.

The 'b' code to inhibit Standalone is '1000'.

9. Spare Fuses

In the event of a fuse blowing on the C4000 Power supply a bag of 3 is included in each flameproof box. Any fuses used from this bag should be replaced

Note: There are three different ratings used. If replacing a fuse, ensure that the correct value is used.

10. Error Messages

Error Code	Fault	Action
Err 3	No price or pump number set.	Set the pump number or: Set a price at the pump or at the controller.
Err 7	Excess flow.	Max Flowrate exceeded
Err 8	Excess reverse rotation of encoder.	Check product is not flowing back into the tank once the delivery has finished.
Err 9	Faulty or disconnected meter encoder.	1. Check that encoder is plugged in. 2. Replace encoder PCB on meter
Err 10	Configuration Lost	Reconfigure C4000 refer to C4000 manual
Err 12	C4000 memory failure.	Change memory IC. F-AD-DS1225 (not applicable to Futra)
Ped Abd	Display error	1. Check display cable for loose wires/crimps 2. Replace display PCB

11. MR400S Spare Parts

Commercial Display
(as shown – includes
backlighting)
F-CP-DISPLAY-COM

Tote
F-BA-TOTE-A-K

C4000 Microprocessor Board
F-CP-C4PROCES-A

Nozzle Holder
F-NOZL-HLDR-COM

COM250 Flowmeter
(complete)
F-METER-COM250AS

COM250 Flowmeter
(electronics)
F-METER-125/250E

ACV Valve
P-VALVE-ACV-2

C4000 Power Supply
(does not include box)
F-CP-C4PWR-ASSEM

Track 2 cardreader
F-BA-CARD-T2C4M

PINPad (Fascia c/w
keypad only)
F-CU-PINPAD-FAS

F-D-SCI08COIL10W
Solenoid Coil
(not visible – on
ACV Valve)

