



compac

INTEGRATED REFUELLING SOLUTIONS

Installation and Setup Instructions

Model: Laser
Version: LL40P
LL80P
LL40/80P

Date of issue: 14 September, 2009

Compac Industries Ltd
P O Box 12-417
Penrose
Auckland
New Zealand
Ph 64 9 5792 094
Fax 64 9 5790 635
www.compac.co.nz

1.	Footprint	3
2.	Static Electricity Precautions	4
3.	Pre-installation Check	4
4.	Comms Dip-switch settings.....	4
4.1	Standard Pump Comms Setting.....	4
4.2	Gilbarco Pump comms Setting	4
5.	Triac Dip-switches	4
6.	Electrical Connections	5
7.	Setting up the C4000	6
7.1	Configuration Codes	6
7.2	Parameter Switch Settings	6
7.3	K-Factor Switch Settings.....	7
8.	Calibration (K-Factor)	8
8.1	Setting the K-Factor	8
8.2	Sealing the K-Factor switch.....	8
8.3	Standalone Operation	9
9.	FST	9
10.	Spare Fuses	9
11.	Error Messages	10
12.	LL40P, LL80P, LL40/80P Spare Parts	11

1. Footprint

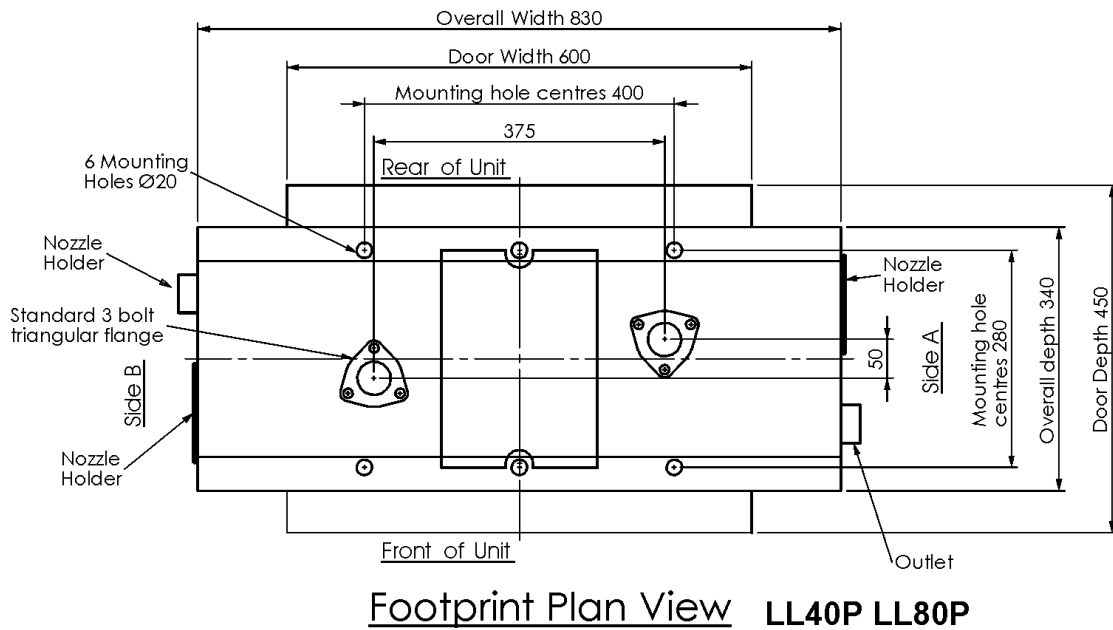
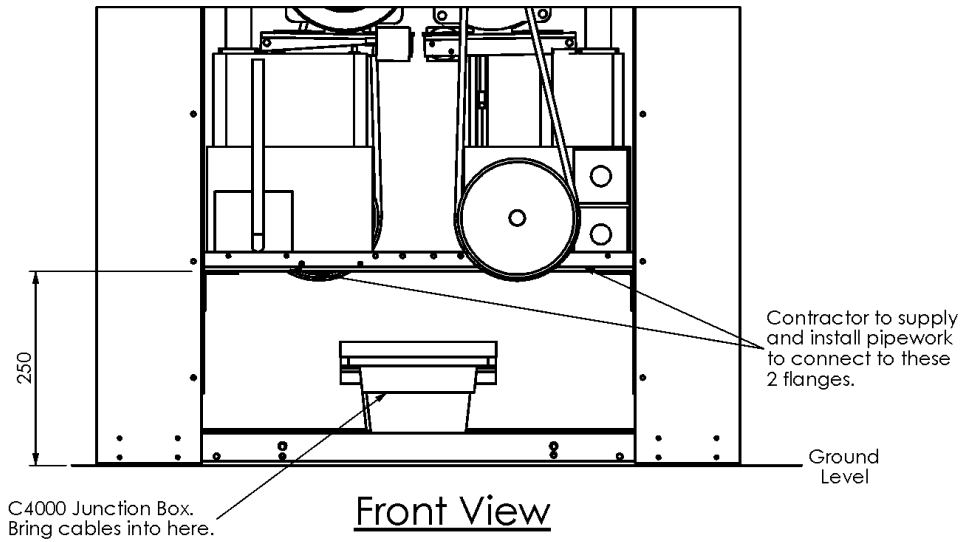

2. Static Electricity Precautions

Electronic components used are sensitive to static. Please take anti-static precautions. An anti-static wrist strap should be worn and connected correctly when working on any electronic equipment. If an anti-static wrist strap is unavailable, or in an emergency, hold onto an earthed part of the pump/dispenser frame whilst working on the equipment. This is not a recommended alternative to wearing an anti-static wrist strap.

Note: Compac Industries Limited reserves the right to refuse to accept any circuit boards returned, if proper anti-static precautions have not been taken.

3. Pre-installation Check

Once the pump is received on site, check that no damage has occurred while in transit – in particular, damage to electronics due to vibration or jarring. All terminals and plugs should be checked, including IC chips, to ensure they are securely in place.

4. Comms Dip-switch settings

4.1 Standard Pump Comms Setting

(Dipswitch SW3)

1-ON

2-OFF

3-ON

4-OFF

These are factory set to the standard setting unless ordered otherwise.eg Gilbarco.

4.2 Gilbarco Pump comms Setting

(Special software and interface board required)

1-OFF

2-ON

3-OFF

4-ON

5. Triac Dip-switches

Important note:

Great care should be taken not to accidentally change the setting of these switches while working in the Flame-proof box. Operating the unit with these incorrectly set can result in damage to the C4000 Power Supply or incorrect operation of the triacs.

These switches are set in the factory and should not be changed.

If they are accidentally changed these are the correct settings for Laser Pump applications. Note: They are 3 position switches

	Pump (Motor triac fitted)
SW1	1
SW2	1
SW4	Centre

6. Electrical Connections

Prior to pump installation ensure that there is at least a two-metre tail on both the incoming underground 230 volt cable and Comms cable. These cables are terminated at the C4000 Power Supply, which is housed in the Flameproof Enclosure located in the bottom of the pump, behind the Door

The incoming cables are terminated as shown in the following picture.

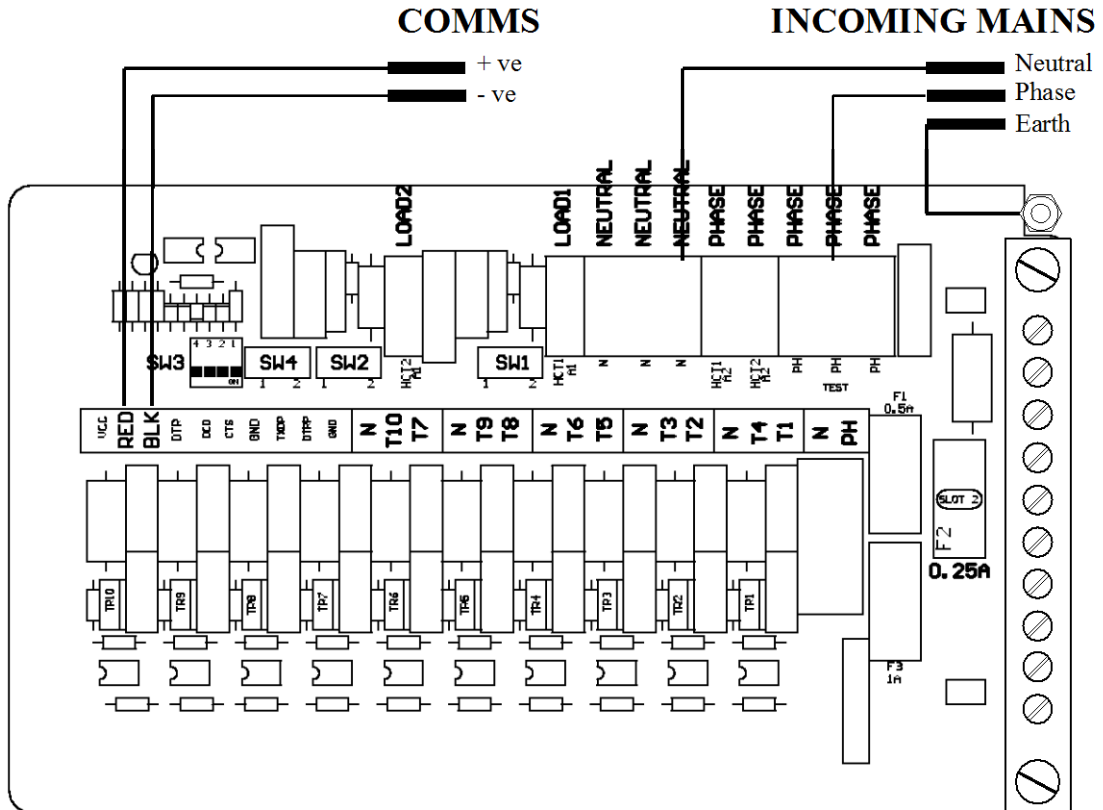

7. Setting up the C4000

Once the pump is connected on site, the final setup check and calibration to complete the installation must be carried out, using the Parameter Switch and Calibration (K-Factor) Switch. These switches are found on the C4000 Microprocessor Board which is housed in a metal enclosure located behind one of the inner column panels.

7.1 Configuration Codes

The configuration code has been set at Compac and should not be changed. In the event of it being lost and having to be re-entered the configuration is written on the yellow label on the C4000 processor board cover.

7.2 Parameter Switch Settings

7.2.1 Setting the Pump Number

This must be set at the pump, for each hose, so that communications with a controller can take place. The location of this switch is shown in the diagram below.

Depress the Parameter Switch nine (9) or more times until the message '**PnA XX**' appears in the litres display window. When the switch is pressed again '**Pnb XX**' will appear on the display. These two options will toggle each time the switch is pressed. To alter either of the pump numbers, press and hold the Parameter Switch when the pump number to be altered appears on the display. This number will then increment. The switch should be released when the desired pump number is displayed. The value of the displayed number will then be stored in the C4000 memory as the pump number for that hose.

NOTE: For a single hose only '**Pn**' will appear

7.2.2 Setting the Price

Using the Parameter Switch, follow the chart to set the price for the hose(s) in question.

Step	ACTION	RESULT
1	Ensure that the nozzle is hung up	Dispenser in idle state
2	Press and Hold the Parameter switch until the "Price per litre" is displayed.	The price for side 'A' is shown as 'PX.XXX' on the litres display and 'PrA' is displayed on the money display.
3	Press and hold the Parameter switch.	A digit, of the displayed 'Price per litre', will begin to increment.
4	When the digit is correct, release the Parameter switch.	
5	Repeat steps 3 and 4 for each digit of the 'Price per litre'.	NOTE: the C4000 will reset itself if the Parameter switch is left for more than 60 seconds.
Continue for Dual hose units		
6	Press and release the Parameter switch 8 or more times in quick succession	The price for side 'B' is shown as 'PX.XXX' on the litres display and 'Prb' is displayed on the money display.
7	Repeat steps 3 to 5 above.	

7.3 K-Factor Switch Settings

K-Factor, and other various configuration settings, are set via this switch. The position of the K-Factor switch is shown in the diagram below:

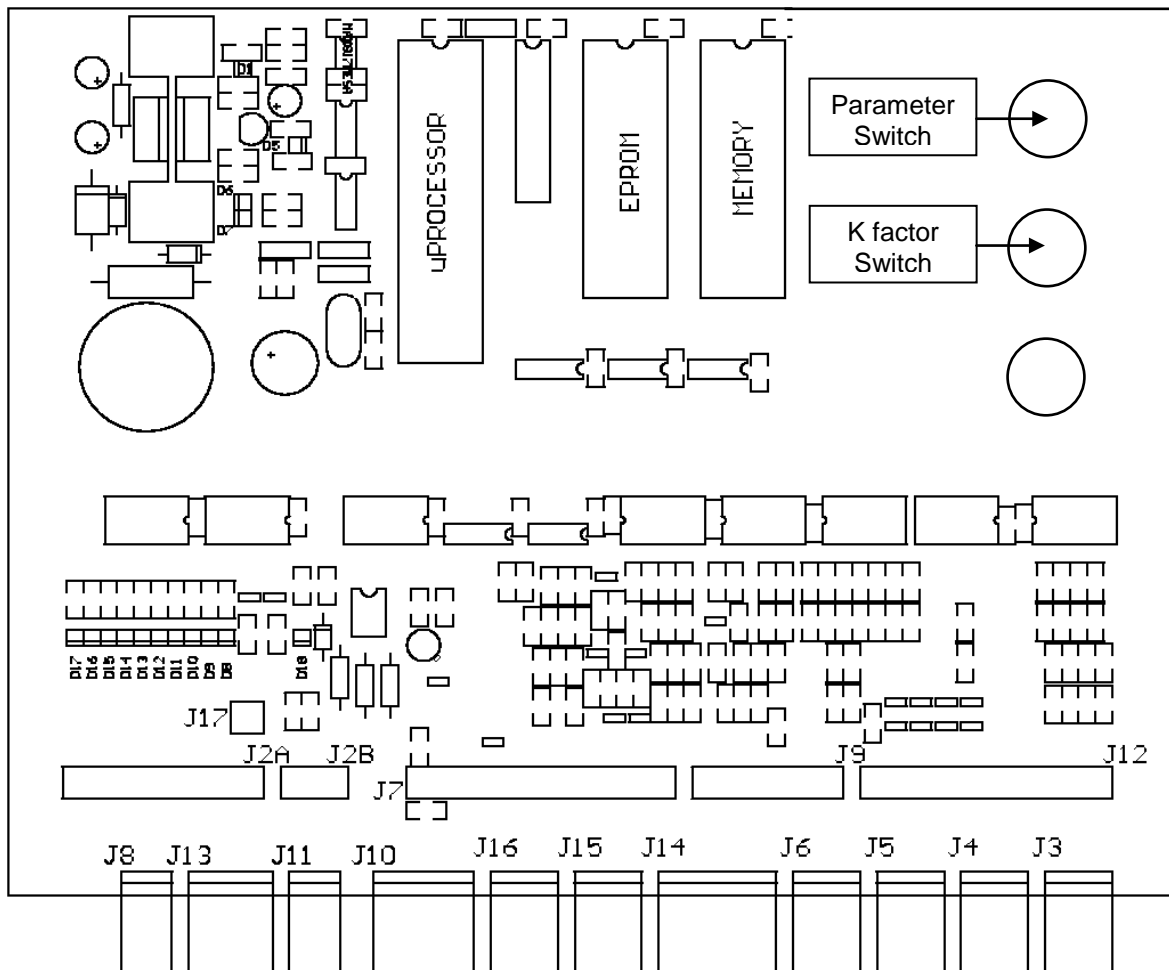

J1: Comms Test	J7: Displays	J13: Not used
J2: To Power Supply	J8: Temperature (for Temperature compensation only)	J14: Not used
J3 : Input from KG Meter Side A	J 9 Power for KG Meters	J15: Not used
J4: Input from KG Meter Side B	J10: Totes	J16: Not used
J5 : Not Used	J11: Buzzer	J17 Backlighting
J6 Not used	J12 Nozzle Switches	

8. Calibration (K-Factor)

8.1 Setting the K-Factor

K-Factor is a proportional calibration factor of litres dispensed per revolution of the meter. To calibrate the dispenser/pump, dispense fuel into a certified measuring container, and compare the display value with the amount dispensed.

Example:

Display shows 10.00

True volume 20.00

To calculate the correct 'K' Factor from the information above; firstly record the existing 'K' Factor.

$$\begin{aligned}\text{New 'K' Factor} &= \text{Existing 'K' Factor} \times \frac{\text{Dispensed Amount}}{\text{Displayed Amount}} \\ &= \text{Existing 'K' Factor} \times \frac{20.00}{10.00} \\ &= \text{Existing 'K' Factor} \times 2\end{aligned}$$

Change the existing 'K' Factor to this new value.

8.2 Sealing the K-Factor switch

After calibration the K-factor switch should be sealed as shown

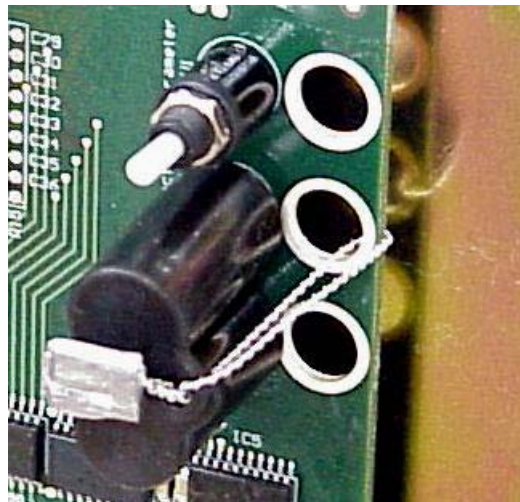

8.3 Standalone Operation

In standalone operation, the dispenser will continue working when not connected to a controller. 'Stand-alone' mode being when no authorisation of fills is required and so fills are simply initiated by removing the refuelling assembly from its holder. If standalone operation is inhibited, the dispenser will not work in 'stand-alone' mode, regardless of whether the dispenser is *ON LINE* to a controller or not.

The dispenser ceases to work in 'stand-alone' mode if connected to a controller, regardless of the position of standalone setting.

Generally on retail forecourts the dispenser should be set-up for standalone operation. Hence, if the forecourt controller breaks down the dispensers can be set to work in 'stand-alone' mode simply by turning them off then on again.

For unattended refuelling sites, the dispensers should not be able to work in 'stand-alone' mode in the event of a controller failure. Therefore the dispenser should be set-up to inhibit standalone operation.

This is set in the 'b' code on the K factor switch.

The 'b' code to run Standalone without Dispenser Controller is '0000'.

The 'b' code to inhibit Standalone is '1000'.

9. FST

(Where fitted)

In Lasers set up for FST units, a 3 core Olex cable is pre-wired to the mains in the flame-proof box. The FST Power Supply end in the display cabinet is fitted with a 3 pin (TYCO 350 689-1) socket wired as follows

Pin 1 Brown (Phase)

Pin 2 Blue (Neutral)

Pin 3 Green (Earth)

No provision is made for comms terminations for the FST unit.

10. Spare Fuses

In the event of a fuse blowing on the C4000 Power supply a bag of 3 is included in each flameproof box. Any fuses used from this bag should be replaced

Note: There are three different ratings used. If replacing a fuse, ensure that the correct value is used.

11. Error Messages

Error Code	Fault	Action
Err 3	No price or pump number set.	Set the pump number or: Set a price at the pump or at the controller.
Err 7	Excess flow.	Max Flowrate exceeded
Err 8	Excess reverse rotation of encoder.	Check product is not flowing back into the tank once the delivery has finished.
Err 9	Faulty or disconnected meter encoder.	1. Check that encoder is plugged in. 2. Replace encoder PCB on meter
Err 10	Configuration Lost	Reconfigure C4000 refer to C4000 manual
Err 12	C4000 memory failure.	Change memory IC. F-AD-DS1225 (not applicable to Futra)
Ped Abd	Display error	1. Check display cable for loose wires/crimps 2. Replace display PCB

12. LL40P, LL80P, LL40/80P Spare Parts

Retail display (includes backlighting)
F-CP-DSPLAY-GD1H

13 key Membrane keypad
F-CP-KPAD-13KM2

Tote
F-BA-TOTE-A-K

C4000 Microprocessor Board
F-CP-C4PROCES-A

Nozzle Holder
F-NOZL-HLDR-M5SR

COM50 Meter
(complete)
F-METER-COM50WPE2

COM50 Meter
(electronics only)
F-METER-50ESP2

Solenoid(complete)
Not shown
F-SOLND-S20-XLGM

Solenoid(Seal kit only)
Not shown
F-SOLND-S20-SK

3/4 HP Electric Motor
F-MOTOR-230-550W

Pump Unit
F-PUMP-ZYB-50
(incl inlet and outlet gaskets)

C4000 Power Supply
(does not include box)
F-CP-C4PWR-ASSEM

Motor Triac
F-AT-BTA40-RD91

