



# C4000 BioBlend Annex

## Version 1.0.0

## **Conditions of Use**

- Read this manual completely before working on or making adjustments to the Compac equipment.
- Compac Industries Limited accepts no liability for personal injury or property damage resulting from working on or adjusting this unit incorrectly or without authorisation.
- Along with any warnings, instructions, and procedures in this manual, you should also observe any other common sense procedures that are generally applicable to equipment of this type.
- Failure to comply with any warnings, instructions, procedures, or any other common sense procedures may result in injury, equipment damage, property damage, or poor performance of the Compac equipment
- The major hazard involved with installing and operating the unit is electrical shock. This hazard can be avoided if you adhere to the procedures in this manual and exercise all due care.
- Compac Industries Limited accepts no liability for direct, indirect, incidental, special, or consequential damages resulting from failure to follow any warnings, instructions, and procedures in this manual, or any other common sense procedures generally applicable to equipment of this type. The foregoing limitation extends to damages to person or property caused by the unit or damages resulting from the inability to use the unit including loss of profits, loss of products, loss of power supply, the cost of arranging an alternative power supply, and loss of time, whether incurred by the user or their employees, the installer, the commissioner, a service technician, or any third party.
- Compac Industries Limited reserves the right to change the specifications of its products or the information in this manual without necessarily notifying its users.
- Variations in installation and operating conditions may affect the unit's performance. Compac Industries Limited has no control over each installation's unique operating environment. Hence, Compac Industries Limited makes no representations or warranties concerning the performance of the unit under the actual operating conditions prevailing at the installation. A technical expert of your choosing should validate all operating parameters for each application.
- Compac Industries Limited has made every effort to explain all servicing procedures, warnings, and safety precautions as clearly and completely as possible. However, due to the range of operating environments, it is not possible to anticipate every issue that may arise. This manual is intended to provide general guidance. For specific guidance and technical support, contact your authorised Compac supplier, using the contact details in the Product Identification section
- Information in this manual shall not be deemed a warranty, representation, or guarantee. For warranty provisions applicable to this unit, please refer to the warranty provided by the supplier.
- Unless otherwise noted, references to brand names, product names, or trademarks constitute the intellectual property of the owner thereof. Subject to your right to use the unit, Compac does not convey any right, title, or interest in its intellectual property, including and without limitation, its patents, copyrights, and know-how.
- Every effort has been made to ensure the accuracy of this document. However, it may contain technical inaccuracies or typographical errors. Compac Industries Limited assumes no responsibility for and disclaims all liability of such inaccuracies, errors or omissions in this publication.

# Contents

Conditions of Use .....	2
Product Identification .....	4
Document Control Information .....	5
Symbols and Units of Measure .....	6
Safety - C4000 Controller.....	7
Static Electricity Precautions.....	7
Introduction .....	8
Software Requirements .....	8
Pre-installation Checks.....	9
Tools Required.....	10
Site Preparation.....	11
Electrical Preparation.....	11
Pipework Preparation.....	11
Footprint.....	13
Installation .....	13
Dispensing Hose and Nozzles .....	14
Wiring.....	14
Setting up the C4000 for Static Blend (Stand Alone Pumps) .....	15
Setting up the C4000 for Dynamic Blend .....	16
Calibration .....	17
Error Codes .....	18
Last Sale Value.....	18
Glossary of Terms.....	19
Installation Checklist .....	20

# Product Identification

<b>Manual Title</b>	<b>C4000 BioBlend Annex</b>
---------------------	-----------------------------

<b>Models Covered</b>	C4000 BioBlend Controller
-----------------------	---------------------------

<b>Application</b>	Power Supply	220 - 240 VAC; 50 Hz; 10 Amp +/- 10%
--------------------	--------------	--------------------------------------

<b>Related Manuals</b>	Title	Publication Date
	C4000 Manual	February 2011
	Pump Installation Sheet	Depends on pump model

<b>Validity</b>	Compac Industries Limited reserves the right to revise or change product specifications at any time. This publication describes the state of the C4000 processor at the time of publication and may not reflect the product at all times in the past or in the future.
-----------------	--

<b>Manufacturer Contact Details</b>	<p>The Compac C4000 processor is designed and manufactured by:</p> <p>Compac Industries Limited                      52 Walls Road, Penrose, Auckland 1061, New Zealand                      P.O. Box 12-417, Penrose, Auckland 1641, New Zealand</p> <p>Phone: + 64 9 579 2094                      Fax: + 64 9 579 0635</p> <p><a href="http://www.compac.co.nz">www.compac.co.nz</a></p> <p>Copyright ©2011 Compac Industries Limited, All Rights Reserved</p>
-------------------------------------	---

# Document Control Information

## Document Information and Revision History

Document Details:	C4000 BioBlend Annex	
File Name and Location:	G:\Masters\Manuals\Authorised Manuals\C4000\BioBlend	
Current Revision Author(s):	R Lacey	
Authorised By:	A Kingstone	Release Date: 12/10/2011

Version	Date	Author(s)	Revision Notes
1.0.0	12/10/2011	R Lacey	Initial release

## Distribution

Name	Indicator	Location

# Symbols and Units of Measure

## Symbols

Symbols are used in this manual to highlight information that is critical to the safety of people and equipment, and for the safe and correct operation of the Compac equipment

**⚠ DANGER** *An extreme hazard that may result in death or injury if proper precautions are not taken.*

**⚠ DANGER** *A reminder of safety practices or unsafe practices that could result in personal injury or damage to associated equipment.*

**⚠ CAUTION** *A reminder of safety practices or unsafe practices that could result in damage to associated equipment and/or voids the warranty.*

**⚠ NOTE** *Important information essential to the installation and operation of the Compac equipment*

## Units of Measure

The following units of measure are used in this manual:

Unit	Measure
Pressure	Bar (bar)
Temperature	Degrees Celsius (°C)
Volume	Litres (L)
	Cubic Metres (m <sup>3</sup> )
Mass	Kilograms (kg)
Length	Metres (m)
	Millimetres (mm)
	Microns, Micrometres (µm)
	Inches (")
Torque	Newton Metres (Nm)
Voltage	Volts (V)
Current	Amps (A)
Frequency	Frequency (Hz)

# Safety - C4000 Controller

You must adhere to the following safety precautions at all times when working on the Compac C4000 processor. Failure to observe these safety precautions could result in damage to the Compac C4000 processor, injury, or death.

*Make sure that you read and understand all safety precautions before operating the Compac Compac C4000 processor.*

## Mechanical Safety

Observe the following mechanical precautions:

**⚠ CAUTION** *Make sure that the service area is thoroughly clean when servicing. Dust and dirt entering the components reduce the life span of the components and can affect operation.*

## Electrical Safety

Observe the following electrical precautions:

**⚠ CAUTION** *Always turn off the power to the Compac C4000 processor before opening the flame proof box. Never touch wiring or components inside the high voltage area with the power on.*

**⚠ CAUTION** *Always turn off the power to the Compac C4000 processor at the mains switch before removing or replacing software or memory ICs.*

**⚠ CAUTION** *Always take basic anti-static precautions when working on the electronics, i.e., wearing a wristband with an earth strap.*

**⚠ CAUTION** *The C4000 head, and its associated circuits and wiring, is a certified piece of electrical equipment approved for use in a hazardous area (Class 1 Zone 1, Group IIA T3). Only parts identical to those covered by the certification may be used where the integrity of the intrinsic safety may be affected. All circuit boards are to be repaired only by Compac Industries Ltd.*

## Static Electricity Precautions

Electronic components used are sensitive to static. Please take anti-static precautions.

All circuit boards must be carried and transported in static-shielded bags. An anti-static wrist strap should be worn and connected correctly when working on any electronic equipment. If an anti-static wrist strap is unavailable, or in an emergency, hold onto an earthed part of the pump/dispenser frame whilst working on the equipment. This is not a recommended alternative to wearing an anti-static wrist strap.

**⚠ NOTE** *Compac Industries Limited reserves the right to refuse to accept any returned circuit boards if proper anti-static precautions have not been taken.*

## Introduction

The Compac C4000 BioBlend controller has been specifically adapted to enable the dispensing of customised mixtures of diesel and bio-diesel fuels.

Using two pumps and solenoids, bio-diesel and diesel are drawn from their respective tanks and blended at a ratio of between 0% to 40% bio-diesel to diesel in 5% increments.

The blend can be selected in two ways:

1) Static Blend. This is set in the C4000 using the parameter switch menu and is used for stand alone pumps with no fuel management system connected. Blend ratios in 5% increments from B00 (0% bio-fuel) to B40 (40% bio-fuel).

2) Dynamic Blend. The blend ratio is set on each fuel card and sent from the ComFMS board to the C4000. Gradients in 5% gradients from B00 (0%) to B40 (40%).

The system works by turning on both pump motors and then pulsing the primary and secondary solenoids of the bio-fuel circuit to achieve the correct blend ratio. Two com50 meters are used, one for each fuel. The combined total of fuel delivered through both meters is displayed on the main pump display.

**NOTE** *The total flow rate of the pump will vary depending on the blend selected. At a low ratio of bio-fuel the flow rate will be lower as the majority of the blend will be supplied by the diesel pump and motor. As the ratio of bio-diesel increases, the total flow rate will increase as the flow will be a combination of both pumps and motors.*

**CAUTION** *The pump is designed to dispense mineral diesel with the addition of bio-diesel. It is not designed to dispense 100% bio-diesel if the mineral diesel tank is empty. Meter errors and fuel overflow through the air eliminator may occur if this is attempted.*

## Software Requirements

For the system to operate correctly special software must be used in the C4000 processor board and the ComFMS board if applicable. The blend percentage can only be controlled through a Compac fuel management system, it is not able to be controlled by a 3rd party system.

Software versions are:

C4000: HIA29253\_BLEND

ComFMS: EAB01828\_BLEND



# Pre-installation Checks

## Transit Damage

Once the unit is received on site, inspect the cabinet for the following:

- Shipping damage to cabinet, display or any other equipment.
- Water damage to components

Report any damage to the transport company and to the help desk.

Take photographs if required.

## Tampering

Inspect for:

- Evidence of tampering with the unit especially card reader or unauthorised wiring.

Report any concerns to the help desk.

Take photographs if required.

## Vibration

Inspect terminals, plugs and IC chips to check they are securely in place and have not loosened due to vibration.

## Site Issues

Check that all wiring and pipework has been installed correctly and is undamaged.

Report issues to site manager.

**⚠ NOTE** *Inappropriate installation may void the warranty. If uncertain, contact your Compac agent for advice.*

## **Tools Required**

### **Tools**

It is expected that installers will carry a comprehensive tool kit including:

- Metric and imperial spanners
- Metric and imperial socket set
- Metric and imperial allen keys
- Torx and security torx keys
- Phillips, pozidriv and flat blade screwdrivers

### **Power Tools**

- Electric impact drill with conventional and masonry drill bits

### **Electrical Tools**

- Wire cutters
- Wire stripper
- Crimping tool
- EPROM extractor
- Multimeter
- Earthing wrist strap

### **Diagnostic Equipment**

- Laptop with fully charged battery and wireless modem
- LAN cable
- Fully charged cell phone
- Test cards and/or authorisation keys

### **Safety Equipment**

- High visibility vest or jacket
- Personal protective equipment (PPE) Boots, gloves, goggles, hearing protection, hard hat etc.
- Cones, barriers, tape to secure your working area

### **Other Equipment**

- Step ladder
- Torch
- Cable ties
- Dynabolts or suitable fasteners to suit the base material
- Cleaning spray and clean cloths

The above list is a suggested minimum. It is recommended that you read the manual thoroughly and include any other equipment that may assist you in completing the job safely and quickly.

## Site Preparation

Refer to the Site Audit document if supplied.

To ensure maximum operating life, care should be taken when siting the dispenser. Considerations should include:

- The unit is not designed to be constantly exposed to the elements. A canopy or shelter should be installed to protect it.
- The card reader and PIN pad should face away from the prevailing wind especially in dusty or wet areas.
- In areas experiencing extremes of weather (heat, cold, wind, rain, salt spray etc.) consideration should be given to installing additional shelter.
- On heavy vehicle sites, mounting the unit on a raised pad and/or installing bollards to help protect from damage.
- The base needs to be attached to a smooth, level surface of sufficient strength to securely hold the retaining bolts or fasteners.

## Electrical Preparation

Power and communication cables must meet or exceed local regulation requirements.

If no local regulations exist, we recommend as a minimum:

Power: 3 core 2.5 mm<sup>2</sup> Steel Wire Armour (SWA) cable

Comms: 2 core 1.5 mm<sup>2</sup> Steel Wire Armour (SWA) cable

There should be a minimum of a 2 metre tail for all wiring

**NOTE** *The length of the communications cable must not exceed 100 metres.*

## Pipework Preparation

Pipework should be laid in accordance with local regulations.

To obtain maximum flow on a self contained pump, observe the following guidelines:

- Total length of horizontal piping between tank and pump should be no longer than 18 metres.
- Piping specifications: For 40 l/min pumps, use 1½" galvanized or approved non-metallic pipe. For 80 l/min pumps use 2" galvanized or approved non-metallic pipe.
- Only one pumping unit is permitted for each underground pipe. Do not use tee joints to connect two pumps into one pipe.
- Pipe must slope up from the tank to the pump (approximately 15 mm per metre). Pipe should be straight and supported along its length.
- All horizontal piping must be buried at least 450mm below ground level.
- The area under the pumping unit(s) must be filled with sand or dirt as far up the suction line as possible. Use water to pack the sand or dirt when put in place.
- Avoid asphalt drive surfaces covering the piping. Asphalt increases heat absorption causing vapour lock.
- Static lift must not exceed 3 metres (vertical distance from the product level in the tank to the centre of the pump unit).
- To absorb ground movement from settling of the tank, frost heaving of the

ground or pump island settling, a swing joint must be used in the supply line at the tank and directly underneath the dispenser. Three additional directional changes using elbows are permitted.

- Piping must hold a 3.4 Bar (50PSI) pressure test for a minimum of 10 minutes.

Refer to the footprint drawings for pump installation details.

### Check Valve

A Check Valve must be installed at the tank end of the suction pipe on the top of the tank in a serviceable location. Many clients install an extra check valve at the inlet to the pump. It is important neither of the check valves interfere with the flow of fuel. They must be adequately sized

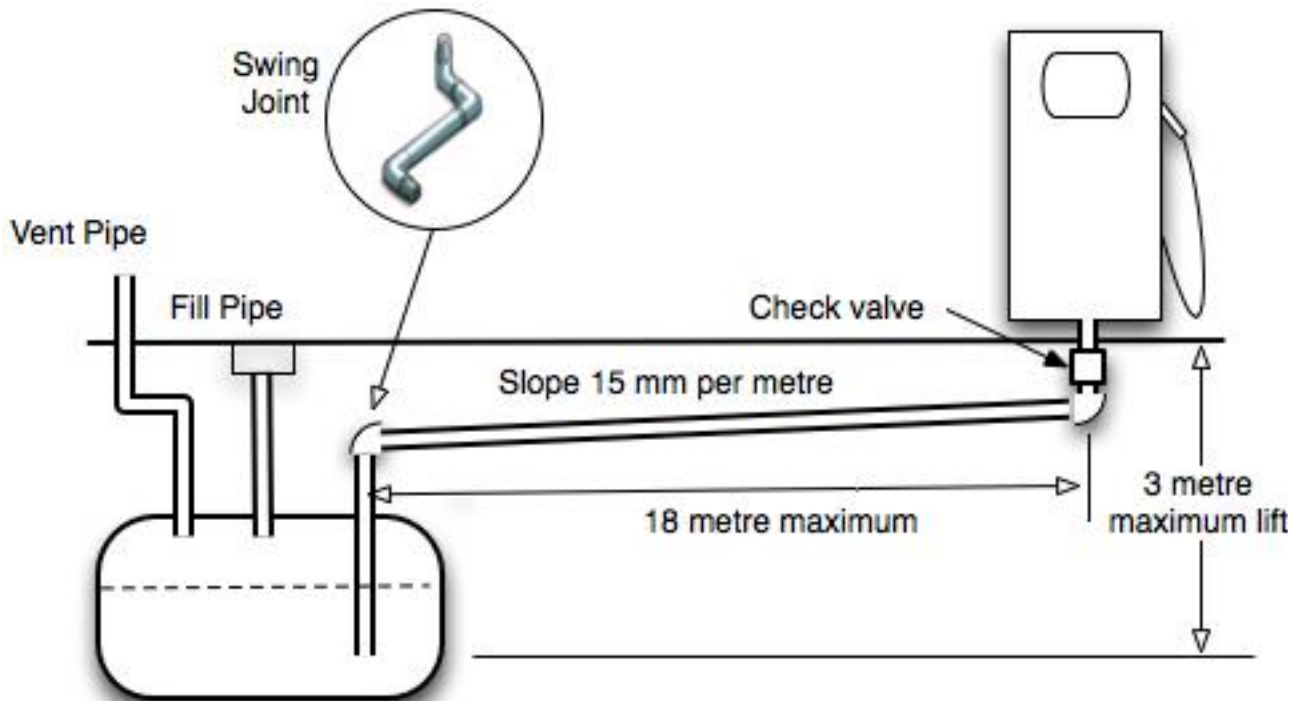

**⚠ DANGER** The pump inlet must not be pressurised at any time. This will cause fuel to flow from the air eliminator. Unregulated connection to an above ground tank will cause pressurisation.

**⚠ DANGER** For above ground tanks a regulator valve such as a Tokheim valve or similar device **MUST** be used so that the inlet of the pump cannot become pressurised at any time.

**⚠ CAUTION** The air switch is not to be disconnected. Disconnection will void NSC and TMU approvals.

**⚠ CAUTION** The air eliminator chamber is not to be piped back to the tank. This will prevent it from working and may damage the pump.

# Footprint

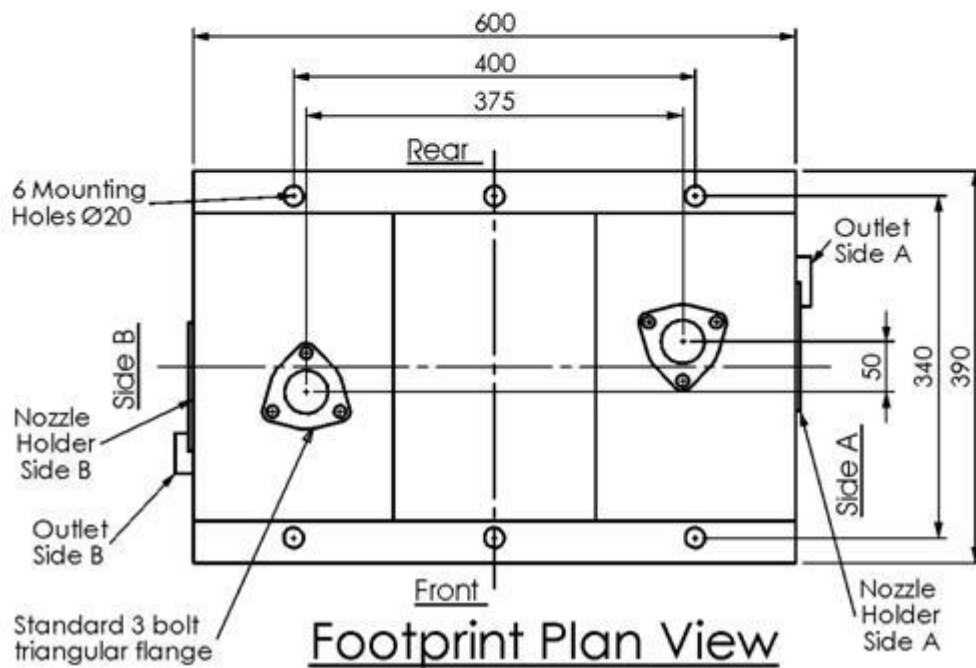
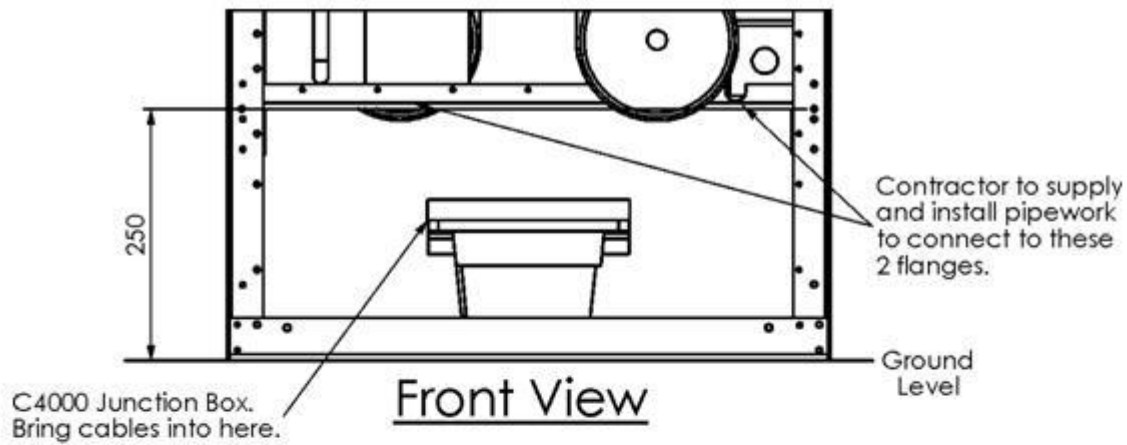

**NOTE** Flanges are labelled A and B. Connect flange A to the mineral diesel tank and flange B to the bio diesel tank.

# Installation

Refer to your individual pump installation sheets for mounting diagrams.

The two inlets on the base of the dispenser are labelled A and B. Ensure that the inlet A is connected to the (mineral) diesel tank and the inlet B is connected to the bio-diesel tank.

## ***Dispensing Hose and Nozzles***

The unit may or may not be supplied with dispensing hose and nozzle assemblies.

The dispensing equipment shall be installed to prevent the delivery hose from contacting the ground when not in use.

If customer supplied hose assemblies, pylons, reels, safe breaks and nozzles are used they must comply with the requirements outlined in AS/NZS 2229

## ***Wiring***

For general wiring instructions, refer to the C4000 Master Manual.

On the C4000 Power Supply the motors and solenoids are connected to the following terminals:

Mineral pump motor is T1

Mineral solenoids are T2 and T3

Bio pump is T4

Bio solenoids are T5 and T6

On the C4000 Board the meters are connected to the following terminals:

Mineral meter plugs into J3

Bio Diesel meter plugs into J4

## **Setting up the C4000 for Static Blend (Stand Alone Pumps)**

For pumps that are not connected to a card management system, the C4000 must be set up to dispense the correct blend using the Parameter Switch.

Refer to C4000 Master Manual to find the location of the parameter switch.

<b>STEP</b>	<b>ACTION</b>	<b>RESULT</b>
1	Ensure that the nozzle is hung up	Dispenser in idle state
2	Press the parameter switch 9 times	The blend ratio is displayed in the following format: bXX where XX is the current blend ratio percentage. Eg. b15 is a 15% blend.
3	Press and hold the Parameter switch.	The blend ratio number will step up in increments of 5% until the maximum ratio of 40% is reached. If the parameter switch is held after this, the ratio will return to zero and start stepping up again.
4	When the ratio is correct, release the Parameter switch.	After approximately 10 seconds the display will return to the normal dispenser display.

**NOTE** *If dynamic (fuel card controlled) blends are used, the set figure will become the default blend setting if the fuel card does not have a blend ratio set.*

## Setting up the C4000 for Dynamic Blend

Set the default bio-fuel blend ratio if required. Refer Setting up the C4000 for Stand Alone BioBlend. (see page 15)

In your card files use the "Owner Details 1" column to manage the individual blend ratios using the following format: BXX where XX is the percentage bio-diesel to diesel blend required. Eg. B10 is a 10% bio-diesel to 90% diesel blend ratio.

Blend ratios must be in steps of 5% and not exceed 40% bio-diesel.

A sample card file is shown below:

	A	B	C	D	E	F	G	H	I
1	Number	Valid	Blend Ratio	Exp Year	Exp Mth	Cost Centre /Card Number	Reg	Account Number	
2	36123013	TRUE	B10	2015	6	5080	456123	ZB3889	712350
3	36123044	TRUE	B15	2015	1	5022	245607	DJF673	712350
4	36123046	TRUE	B10	2015	12	5093	545688	COM175	712350
5	31235049	TRUE	B20	2015	10	5093	567868	AGG125	712350
6	36123050	TRUE	B10	2014	12	5030	289608	APA405	712350
7	36123054	TRUE	B00	2015	12	5093	556720	GAC240	712350
8	36434557	TRUE	B05	2014	7	5093	154314	CAF815	712350



# Calibration

To calibrate a BioBlend dispenser use the following procedure:

Refer to C4000 Master Manual for detailed instructions.

1. Change the B configuration to b0000 as it will be set to inhibit standalone. (b1000 is standard)
2. Change the C config to be C00001
3. Disconnect the communications from the FMS board or simply turn off the power switch in the ComFutra head and then re-power the pump to put it into standalone mode
4. Calibrate the Mineral side of the dispenser using the normal calibration procedures. Refer to C4000 manual.
5. Change the C Config to be C00002
6. Calibrate the mineral side of the dispenser using normal calibration procedures
7. Change the C Config to C00003 to enable the blend
8. Check the Blend is set to 10% in the B config (b10)
9. Do a couple of test fills and confirm you get a 10% blend. This can be done by filling a 20L pail and then checking after the fill that approx 2 litres of bio-fuel is shown in the Litres display by using the Last Sale Value function of the Parameter menu.
10. Change the B configuration back to b1000 to re-enable inhibit standalone, reconnect the comms and turn on the ComFutra head.
11. Wait a few minutes for the ComFutra to boot up then do a test fill or two using a card to confirm that everything works and you are still getting the correct blend ratio.

## Calibration Codes

Code	
C = 00001	Calibration mode – Meter side A
C = 00002	Calibration mode – Meter side B
C = 00003	Blend mode – Both meters

**NOTE** All other C config codes are disabled.

## **Error Codes**

Error codes 7, 8 and 9 now have an “A” or “B” prefix with the A prefix denoting an error on the mineral fuel side and “B” being used for the Bio Diesel errors

An Air switch error is displayed as ‘A Air’ or ‘b Air’

If the pump is not able to deliver the blend or the blend percentage being delivered differs more than 3% from the requested ratio, the C4000 will stop both motors and display a ‘blend’ error. If this happens the user needs to check all supply valves and fuel levels. They can then re-authorise the pump and attempt another delivery, the equipment does not need to be re-powered to clear the error.

 **NOTE** Refer to the C4000 Master Manual for a complete list of error codes.

## **Last Sale Value**

Using the parameter switch, scroll past the pump number. The display will show last sale values for: Meter A (diesel) litres in the Amount display, Meter B (bio-diesel) litres in the Litres display, and the blend ratio used in the unit price display.

For commercial pumps with a Litres only display, the dispensed quantity of bio-diesel only will be displayed in the litres display.

# Glossary of Terms

TERM	DESCRIPTION
<b>ATG</b>	Automatic Tank Gauging
<b>Class 1 Zone 0</b>	An area in which an explosive-gas atmosphere is present continuously or is present for long periods.
<b>Class 1 Zone 1</b>	An area in which an explosive-gas atmosphere is likely to occur in normal operation.
<b>Class 1 Zone 2</b>	An area in which an explosive-gas atmosphere is not likely to occur in normal operation, and if it does occur it will exist for short periods only.
<b>ComFutra</b>	A model of pump mounted authorisation terminal made by Compac.
<b>CPU</b>	Central Processing Unit.
<b>CWID</b>	Compac Wireless Identifier.
<b>DCA</b>	Driveway Card Acceptor - A type of pump authorisation terminal made by Compac.
<b>Encoder</b>	A device that translates rotary motion into electronic pulses. Often referred to as a pulser.
<b>Head</b>	Dispenser calculator/Indicator. C4000 PCB, complete with power supply.
<b>HID</b>	Transponder key authorisation system
<b>Intrinsically safe circuit</b>	A circuit in which any spark or any thermal effect produced in the test conditions prescribed in the relevant standard (which includes normal operation and specified fault conditions) is incapable of causing ignition of a given explosive atmosphere.
<b>Intrinsically safe electrical equipment</b>	Electrical equipment in which all the circuits are intrinsically safe. The equipment may be self-contained or may form part of an intrinsically safe electrical system.
<b>Intrinsically safe electrical system</b>	An assembly of interconnected items of electrical equipment in which the circuits or parts of circuits, intended to be used in an explosive atmosphere, are intrinsically safe circuits.
<b>LED</b>	Light emitting diode.
<b>Memory chip</b>	EPROM chip that stores parameters and/or transaction & totals.
<b>OPT</b>	Outdoor Payment Terminal - A type of authorisation terminal designed for credit card applications made by Compac.
<b>PCB</b>	Printed Circuit Board.
<b>RAS</b>	Retail Authorisation Station - Authorisation terminal designed for manned sites
<b>Via</b>	'Plated through hole' in a PCB that enables tracks to swap sides on a PCB.
<b>Software chip</b>	EPROM chip with label indicating program version.

# Installation Checklist

Version 1.0.0.

Covers Compac DCA, Comfutra, Card King and Controller units.

Site number and name:	
Date:	
Installer name and phone number:	
Terminal ID number:	

When a new unit is being installed use the following checklist to make sure the unit is fully operational. Check each box or write N/A where not applicable. Refer to the relevant installation manual for procedures.

**Mechanical Checks**

Yes No

Check unit is undamaged and has not been tampered with.	<input type="checkbox"/>	<input type="checkbox"/>
Is the unit in a sheltered position and facing away from the prevailing wind and rain?	<input type="checkbox"/>	<input type="checkbox"/>
Check all panels are securely fastened using tamper-proof fastenings where supplied.	<input type="checkbox"/>	<input type="checkbox"/>
Check that all cable entries to unit are through glands.	<input type="checkbox"/>	<input type="checkbox"/>

**Power on Checks**

Yes No

Check that the CE board, FMS board, pinpad, printer, cardreader, router and modem all power up.	<input type="checkbox"/>	<input type="checkbox"/>
Check pumps are re-priced to the current fuel price.	<input type="checkbox"/>	<input type="checkbox"/>
Check that different fuels are correctly priced on all hoses.	<input type="checkbox"/>	<input type="checkbox"/>

**Transaction Checks**

Yes No

Complete transaction using white card/CWID/HID/Pin authorisation methods	<input type="checkbox"/>	<input type="checkbox"/>
Complete transaction using credit card (credit card DCA only).	<input type="checkbox"/>	<input type="checkbox"/>
Check that all hoses can be selected and authorised by the unit.	<input type="checkbox"/>	<input type="checkbox"/>
Check all hoses stop on or before the pre-authorised value (credit card DCA only).	<input type="checkbox"/>	<input type="checkbox"/>

**Receipt Checks (where fitted)**

Yes No

Check that the correct \$, L and fuel grade are printed on the receipt.	<input type="checkbox"/>	<input type="checkbox"/>
Check the date, time and header information is correct.	<input type="checkbox"/>	<input type="checkbox"/>

**USB Module Checks (where fitted)**

Yes No

Check the supplied USB key is recognised by the unit.	<input type="checkbox"/>	<input type="checkbox"/>
Select "Get Transactions" and check that transactions are uploaded to the USB key.	<input type="checkbox"/>	<input type="checkbox"/>

**CompacOnline Checks (when connected)**

Yes No

Check the site appears on CompacOnline.	<input type="checkbox"/>	<input type="checkbox"/>
Check that transactions have been recorded on CompacOnline.	<input type="checkbox"/>	<input type="checkbox"/>

**Tank Gauging Checks (where fitted)**

Yes No

Check that tanks are set up in CompacOnline and that correct levels are being reported.	<input type="checkbox"/>	<input type="checkbox"/>
Check that the correct products are assigned to the correct tanks.	<input type="checkbox"/>	<input type="checkbox"/>

**Customer Training**

Yes No

Check site attendants understand refuelling procedures.	<input type="checkbox"/>	<input type="checkbox"/>
Check that site administrators understand how to obtain transactions and administer cards.	<input type="checkbox"/>	<input type="checkbox"/>

**Final Checks**

Yes No

Ensure all cables are plugged back in after remote accessing.	<input type="checkbox"/>	<input type="checkbox"/>
Tidy up all rubbish and clean the exterior of the unit before leaving.	<input type="checkbox"/>	<input type="checkbox"/>

If one or more of these tests fail, contact the Compac help desk or your service centre so the problem can be logged and parts issued if required.

**Notes**

To validate warranty and receive future help desk assistance please fax both sides of this form to: +64 9 579 0635 or post to: Compac Industries Ltd, PO Box 12 417 Penrose, Auckland 1642, New Zealand.	Report any damage immediately to Compac Industries on: +64 9 579 2094. Any site safety issues should be reported immediately to the site manager.
--	---