



***compac***

***PREMIUM DISPENSER TECHNOLOGY***

## **Installation Manual**

### **Version No 1.0.2**

**Model: Master 4-Hose Tank Dispenser MMR160-40SQ Diesel**  
**Date: 27<sup>th</sup> February 2019**



## Conditions of Use

- Read this manual completely before working on, or making adjustments to, the Compac equipment
- Compac Industries Limited accepts no liability for personal injury or property damage resulting from working on or adjusting the equipment incorrectly or without authorization.
- Along with any warnings, instructions, and procedures in this manual, you should also observe any other common sense procedures that are generally applicable to equipment of this type.
- Failure to comply with any warnings, instructions, procedures, or any other common sense procedures may result in injury, equipment damage, property damage, or poor performance of the Compac equipment
- The major hazard involved with operating the Compac C4000 processor is electrical shock. This hazard can be avoided if you adhere to the procedures in this manual and exercise all due care.
- Compac Industries Limited accepts no liability for direct, indirect, incidental, special, or consequential damages resulting from failure to follow any warnings, instructions, and procedures in this manual, or any other common sense procedures generally applicable to equipment of this type. The foregoing limitation extends to damages to person or property caused by the Compac C4000 processor, or damages resulting from the inability to use the Compac C4000 processor, including loss of profits, loss of products, loss of power supply, the cost of arranging an alternative power supply, and loss of time, whether incurred by the user or their employees, the installer, the commissioner, a service technician, or any third party.
- Compac Industries Limited reserves the right to change the specifications of its products or the information in this manual without necessarily notifying its users.
- Variations in installation and operating conditions may affect the Compac C4000 processor's performance. Compac Industries Limited has no control over each installation's unique operating environment. Hence, Compac Industries Limited makes no representations or warranties concerning the performance of the Compac C4000 processor under the actual operating conditions prevailing at the installation. A technical expert of your choosing should validate all operating parameters for each application.
- Compac Industries Limited has made every effort to explain all servicing procedures, warnings, and safety precautions as clearly and completely as possible. However, due to the range of operating environments, it is not possible to anticipate every issue that may arise. This manual is intended to provide general guidance. For specific guidance and technical support, contact your authorised Compac supplier, using the contact details in the Product Identification section.
- Only parts supplied by or approved by Compac may be used and no unauthorised modifications to the hardware or software may be made. The use of non-approved parts or modifications will void all warranties and approvals. The use of non-approved parts or modifications may also constitute a safety hazard.
- Information in this manual shall not be deemed a warranty, representation, or guarantee. For warranty provisions applicable to the Compac C4000 processor, please refer to the warranty provided by the supplier.
- Unless otherwise noted, references to brand names, product names, or trademarks constitute the intellectual property of the owner thereof. Subject to your right to use the Compac C4000 processor, Compac does not convey any right, title, or interest in its intellectual property, including and without limitation, its patents, copyrights, and know-how.
- Every effort has been made to ensure the accuracy of this document. However, it may contain technical inaccuracies or typographical errors. Compac Industries Limited assumes no responsibility for and disclaims all liability of such inaccuracies, errors, or omissions in this publication.

## Product Identification

### Specifications

#### Models Covered

This manual applies to the MMR160-40SQ Diesel 4-Hose Tank Dispenser

**NOTE:** Do not use this manual for earlier models. Contact Compac for archived manuals if required.

### Validity

Compac Industries Limited reserves the right to revise or change product specifications at any time. This publication describes the state of the product at the time of publication and may not always reflect the product in the past or in the future.

#### Manufactured By:

The Compac 4-Hose Tank Dispenser is designed and manufactured by Compac Industries Limited

52 Walls Road, Penrose, Auckland 1061, New Zealand

P.O. Box 12-417, Penrose, Auckland 1641, New Zealand

Phone: + 64 9 579 2094

Fax: + 64 9 579 0635

Email: [techsupport@compac.co.nz](mailto:techsupport@compac.co.nz)

[www.compac.biz](http://www.compac.biz)

Copyright ©2015 Compac Industries Limited, All Rights Reserved

CONDITIONS



## Document Control

Document Information	
<b>Manual Title</b>	Master 4-Hose Tank Dispenser MMR160-40SQ Diesel
<b>Current Revision Author(s)</b>	S Laycock
<b>Original Publication Date</b>	12/02/2019
<b>Authorised By</b>	W Zheng

Revision History			
Version	Date	Author(s)	Revision Notes
1.0.0	12/02/2019	R Liu	New Manual
1.0.1	20/02/2019	R Liu	Updated Electronics Layout
1.0.2	27/02/2019	S Laycock	Removed electrical diagram. Edited set-up information.

## Contents

Product Identification .....	3
Footprints .....	4
Installation .....	5
Static Electricity Precautions .....	5
Pre-installation Check .....	5
Procedures .....	5
Comms Dip-switch Settings .....	5
Triac Dip-switches .....	6
Electrical Connections .....	7
Dispensing Hoses and Nozzles .....	8
Setting up the C4000 .....	9
Configuration Codes.....	9
Submersible Delay (Sd).....	9
K-Factor Switch Settings.....	11
Calibration (K-Factor) .....	12
Standalone Operation .....	13
Notes .....	14
Pump Controller .....	14
Spare Fuses .....	14
Precautions if Using Generator Power .....	14
Error Messages .....	15

## Product Identification

Ensure you are using the correct installation instructions and footprint drawing before commencing site work or installation.

The identification plate is fastened to the bottom of the right-hand side panel when facing the front of the dispenser.

The model number is on the first line of the identification plate.

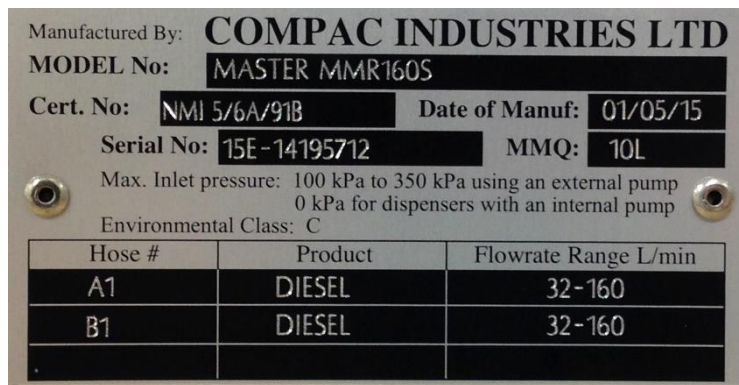

### Understanding the Model Number:

The model number for Master dispensers is split into: Chassis style, hose configuration, pump or dispenser and specific application.

Use the table below to help identify the unit.

Style	L/min per hose	Pump style	Options
MR = single hose	MR40 = one hose @ 40 l/min	P = pump	Blank = Standard
MMR = multi hose	MMR40 = two hoses @ 40 l/min	S = dispenser	Avi = Aviation
	MMR80-40 = side A 80, side B 40		Marine = Marine

For example: MMR 80-40S Marine is a two-hose unit. Hose side A is 80 l/min, side B is 40 l/min with external pumps. As a marine model it has stainless steel pipework and stainless-steel chassis for marine conditions.

**NOTE:** Make sure you use the footprint that relates exactly to your model.

# Footprints

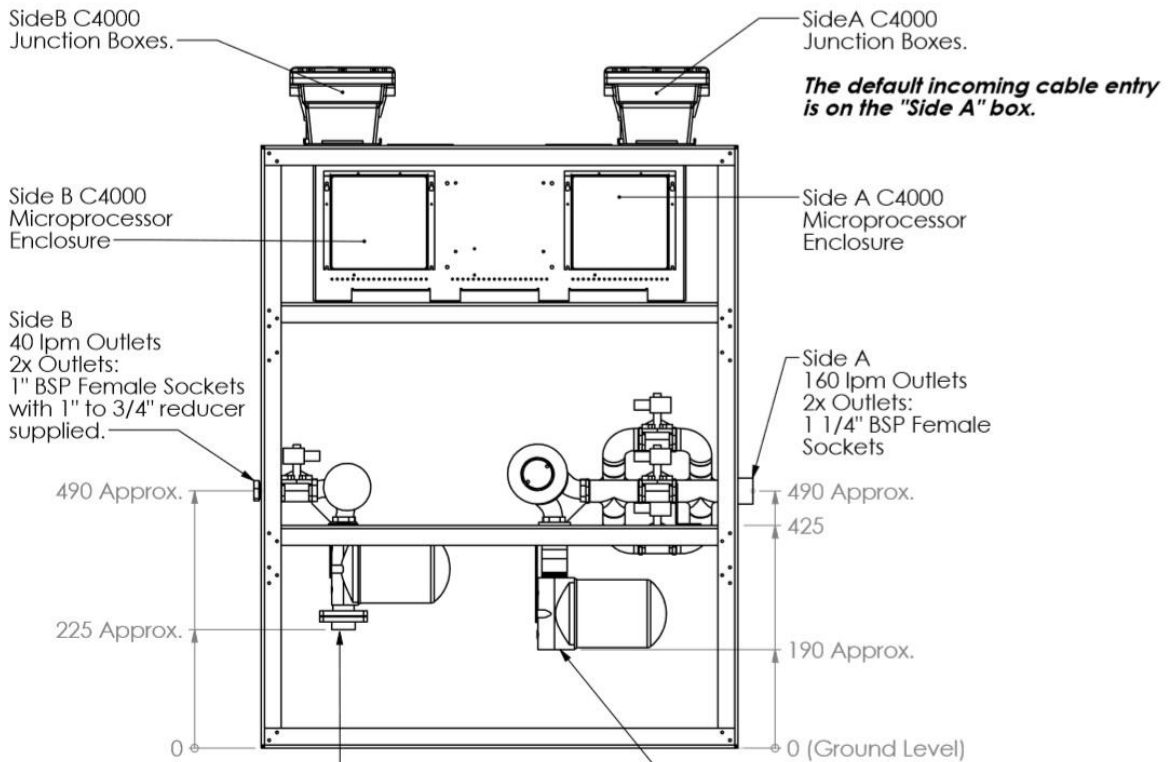

**Front View**

Side A 160lpm Inlets:  
Contractor to supply and install pipework to connect to (2x) 1 1/2" BSP Female threads on the Filter Housings.

Side B 80lpm Inlets:  
Contractor to supply and install pipework to connect to (2x) 1" BSP Female threads on the Triangular Flanges.

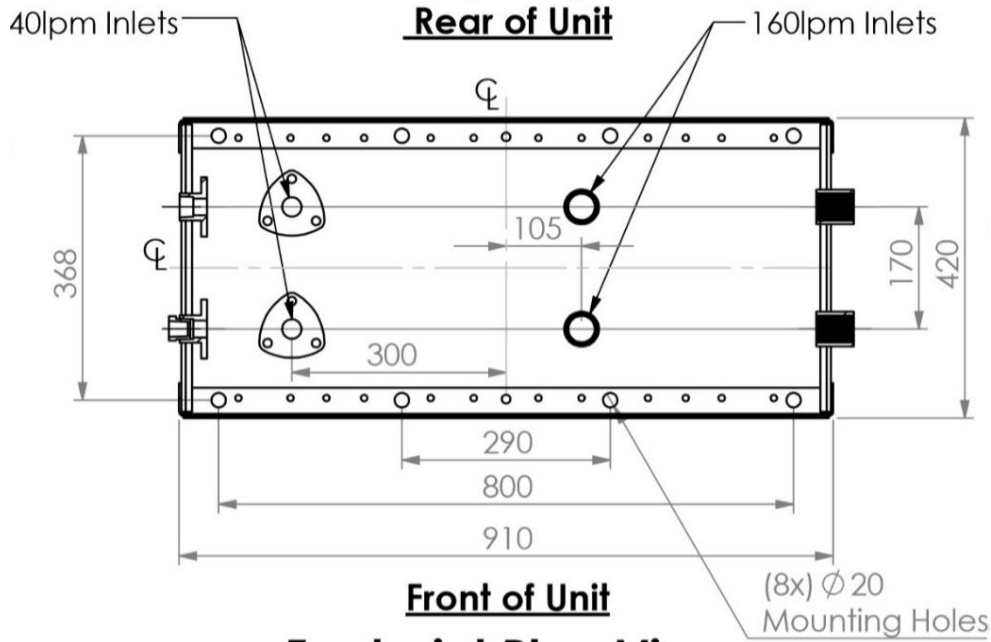

**Front of Unit**  
**Footprint Plan View**

**Footprints**

## Installation

### Static Electricity Precautions

Electronic components used are sensitive to static. Please take anti-static precautions.

An anti-static wrist strap should be worn and connected correctly when working on any electronic equipment. If an anti-static wrist strap is unavailable, or in an emergency, hold onto an earthed part of the pump/dispenser frame whilst working on the equipment. This is not a recommended alternative to wearing an anti-static wrist strap.

**NOTE:** *Compac Industries Limited reserves the right to refuse to accept any circuit boards returned, if proper anti-static precautions have not been taken.*

### Pre-installation Check

Once the pump is received on site, check that no damage has occurred while in transit – in particular, damage to electronics due to vibration or jarring. All terminals and plugs should be checked, including IC chips, to ensure they are securely in place.

### Procedures

Installation should be in accordance with local regulations.

The dispensing equipment shall be installed to prevent the delivery hose from contacting the ground when not in use.

Where local regulations require a sump to be fitted:

- a. Sumps must be provided at all dispenser installations with secondary containment pipework and at all new installations.
- b. At all sites with sumps, dispensers should be installed with a liquid level detection device fitted in the sump that will raise an alarm if liquid is detected in the base of the sump.

### Comms Dip-switch Settings

The actual Comms I/O is controlled by the position of SW3.

SW3	Comms Protocol
Position 1	Compac Standard
Position 2	Gilbarco
Position 3	RS485



## Triac Dip-switches

### ***Important note:***

Great care should be taken not to accidentally change the setting of these switches while working in the Flame-proof box. Operating the unit with these incorrectly set can result in damage to the C4000 Power Supply or incorrect operation of the triacs.

These switches are set in the factory and should not be changed.

If they are accidentally changed these are the correct settings for Master / Premier Dispenser applications.

**NOTE:** *They are 3 position switches*

Dispenser (low current output)	
SW1	2
SW2	2
SW4	2

## Electrical Connections

The instructions below refer to basic installation wiring. For full wiring specifications refer to drawing AP375 available on the Resources section of the Compac website. Prior to pump installation ensure that there is at least a two-metre tail on both the incoming underground mains supply cable and comms cable (if comms enabled). These cables are terminated at the C4000 power supplies, which are housed on the top of the unit.

Mains power wiring should be rated for a maximum current draw of 10 A rms at 220-240 V ac.

The incoming cables are terminated as shown in the figure below. Refer to AS/NZS 60079.14 for appropriate cabling.

**NOTE:** All cables entering the power supplies must be glanded with approved 20mm flameproof glands.

**NOTE:** Output to submersible pump(s) is 230 V ac, 300 mA max. It is wired to the pump contactor/relay at the switchboard and not directly to the pump.

**NOTE:** Comms cable is not intrinsically safe.

**NOTE:** Pump comm's connect to pump controller such as DCA, Communicator Controller etc. (option).

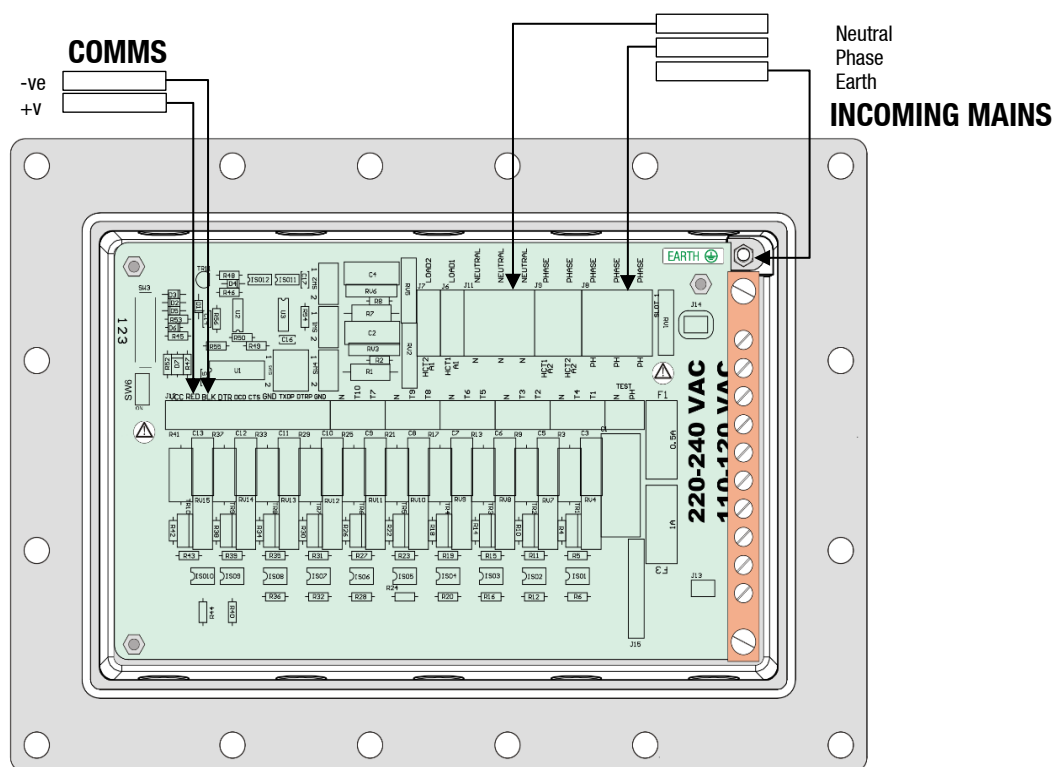

**NOTE:** The dispenser has two power supplies which are interconnected. Mains and comms connections only need to be connected to one power supply. The Side A C4000 Power Supply is the default incoming cable entry, but either side can act as the incoming cable entry.

### Submersible Pump Connections

Connect the feeds to the submersible pump relays / contactors to the C4000 Power Supply as follows:

- Pump supplying side A to terminal marked T1
- Pump supplying side B to terminal marked T4

If both sides are required to switch the same submersible pump then T1 and T4 should be linked together.

**NOTE:** *Dispensers do not use the terminals marked LOAD 1 & 2.*

### Dispensing Hoses and Nozzles

The unit may or may not be supplied with dispensing hose and nozzle assemblies.

If customer supplied hose assemblies, pylons, reels, safe breaks and nozzles are used they must comply with the requirements outlined in AS/NZS 2229.

### Breakaways

For all dispensers fitted with breakaways, ensure the breakaway is installed between the nozzle and the high-mast or pylon (if fitted). Any breakaways that have been subject to a break-away situation should be inspected and refitted or replaced in accordance with the original manufacturer's instructions.

## Setting up the C4000

Once the dispenser is connected on site, the final setup check and calibration to complete the installation must be carried out, using the Parameter Switches and Calibration (K-Factor) Switches (the location of these can be viewed on page 11.)

These switches are found on the C4000 Microprocessor Boards which are housed in metal enclosures located below each power supply.

Four hose dispensers have two power supplies, and therefore all settings (pump number, price etc) should be set for BOTH power supplies. The pump numbers for each hose should be different. The power supply on side B controls both 40lpm pumps, while the side A power supply controls 160lpm pumps.

### Configuration Codes

The configuration code has been set at Compac and should not be changed. In the event of it being lost and having to be re-entered the configuration is written on the yellow label on the C4000 processor board cover.

### Submersible Delay (Sd)

This is the time delay from when the submersible pump starts to when the solenoids in the dispenser open to allow time for the leak detector to reset. This is factory set by Compac at 005 (five seconds).

If problems are experienced with the leak detector tripping, firstly check that **Sd** is still set and then, if necessary, make it longer as follows.

1. On the required microprocessor board, press and release the K factor switch repeatedly until **Sd** appears on the Dollar display. **d\*\*\*** will appear in the litres display.
2. Continue to press the K factor switch until the number to be changed flashes. Hold the switch down and this number will then increment.
3. Release the switch when the required number is displayed. The value of the displayed number will then be stored in the C4000 memory as the submersible delay.

### Setting the Pump Number

This must be set at the pump for each hose, so that communications with a controller can take place. Two pump numbers should be set for each power supply.

1. Depress the Parameter Switch nine (9) or more times until the message **PrA** \*\* appears in the litres display window. When the switch is pressed again **Prb** \*\* will appear on the display. These two options will toggle each time the switch is pressed.
2. To alter either of the pump numbers, press and hold the Parameter Switch when the pump number to be altered appears on the display. This number will then increment.
3. The switch should be released when the desired pump number is displayed. The value of the displayed number will then be stored in the C4000 memory as the pump number for that hose.

### Setting the Price

Using the Parameter Switch, follow the chart to set the price for the hose(s) in question.

Step	ACTION	RESULT
1	Ensure that the nozzle is hung up	Dispenser in idle state
2	Press and Hold the Parameter switch on the required microprocessor board until the "Price per litre" is displayed.	The price for side <b>A</b> is shown as <b>P****</b> on the litres display and <b>Pr A</b> is displayed on the money display.
3	Press and hold the Parameter switch.	A digit, of the displayed 'Price per litre', will begin to increment.
4	When the digit is correct, release the Parameter switch.	
5	Repeat steps 3 and 4 for each digit of the 'Price per litre'.	<b>NOTE:</b> the C4000 will reset itself if the Parameter switch is left for more than 60 seconds.
6	Press and release the Parameter switch 8 or more times in quick succession	The price for side <b>b</b> is shown as <b>P****</b> on the litres display and <b>Pr b</b> is displayed on the money display.
7	Repeat steps 3 to 5 above.	

## K-Factor Switch Settings

K-Factor, and other various configuration settings, are set via this switch. The position of the K-Factor switch on the microprocessor board is shown in the diagram below.

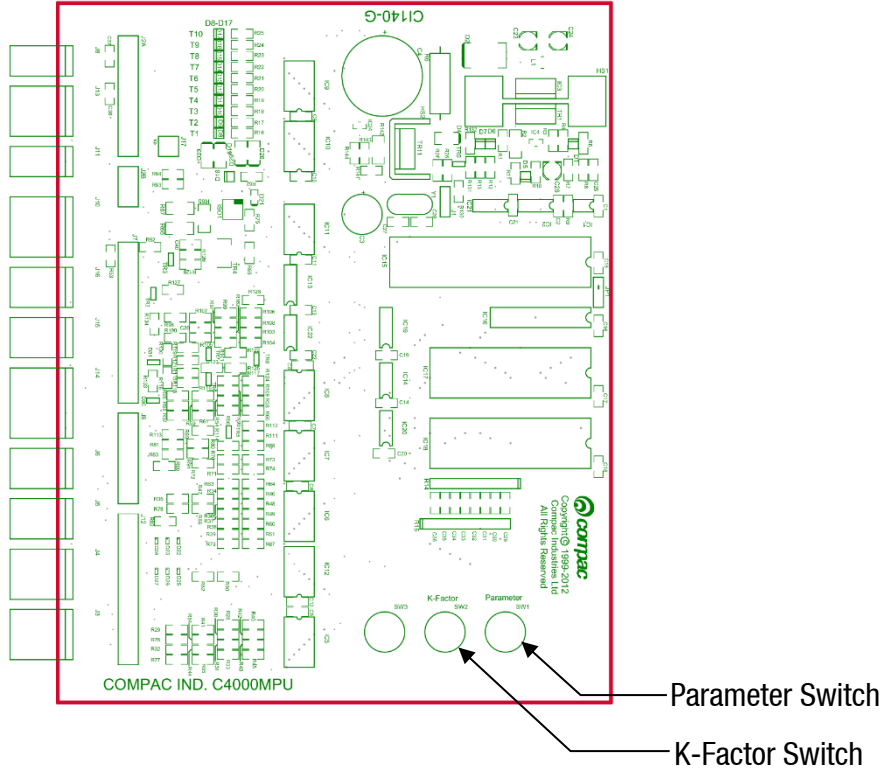

J1: Comms Test	J7: Displays	J13: Not used
J2: To Power Supply	J8: Temperature (for Temperature compensation only)	J14: Not used
J3 : Input from KG Meter Side A	J 9 Power for KG Meters	J15: Not used
J4: Input from KG Meter Side B	J10: Totes	J16: Not used
J5 : Not Used	J11: Buzzer	J17 Backlighting
J6 Not used	J12 Nozzle Switches	

## Calibration (K-Factor)

### Setting the K-Factor

K-Factor is a proportional calibration factor of litres dispensed per revolution of the meter. As there are four meters in four hose dispensers, the procedure to calibrate the K-Factor will have to be completed four times (one time for each meter.)

To calibrate the dispenser, dispense fuel from one hose into a certified measuring container, and compare the display value with the amount dispensed.

#### Example:

Display shows 10.00

True volume 20.00

To calculate the correct 'K' Factor from the information above; firstly, record the existing 'K' Factor.

$$\begin{aligned}
 \text{New K Factor} &= \text{Existing K Factor} \times \frac{\text{Dispensed Amount}}{\text{Displayed Amount}} \\
 &= \text{Existing K Factor} \times \frac{20}{10} \\
 &= \text{Existing K Factor} \times 2
 \end{aligned}$$

To change the existing 'K' Factor to this new value, depress the K-Factor switch on the desired processor board until F1 is shown in the dollars display. Press and hold the K-Factor switch to increment a digit, once flashing. Continue depressing the K-Factor switch to cycle through the digits. F2 is displayed for the second hose.

### Sealing the K-Factor Switch

After calibration the K-factor switch should be sealed as shown:

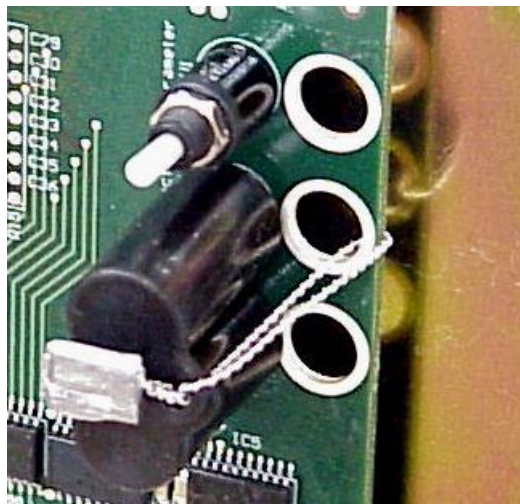

## Standalone Operation

In standalone operation, the dispenser will continue working when not connected to a controller. '*Stand-alone*' mode being when no authorisation of fills is required and so fills are simply initiated by removing the refuelling assembly from its holder. If standalone operation is inhibited, the dispenser will not work in '*stand-alone*' mode, regardless of whether the dispenser is *ON LINE* to a controller or not.

The dispenser ceases to work in '*stand-alone*' mode if connected to a controller, regardless of the position of standalone setting.

Generally, on retail forecourts the dispenser should be set-up for standalone operation. Hence, if the forecourt controller breaks down the dispensers can be set to work in '*stand-alone*' mode simply by turning them off then on again.

For unattended refuelling sites, the dispensers should not be able to work in '*stand-alone*' mode in the event of a controller failure. Therefore, the dispenser should be set-up to inhibit standalone operation.

This is set in the **b** code on the K factor switch.

The **b** code to run Standalone without Dispenser Controller is **0000**.

The **b** code to inhibit Standalone is **1000**.



## Notes

### Pump Controller

If the pump is connected to a controller, check that pump data and transaction information is being correctly uploaded to it. Refer to the controller manual for specific instructions regarding connection and setup.

### Spare Fuses

In the event of a fuse blowing on the C4000 Power supply a bag of 3 is included in each flameproof box. Any fuses used from this bag should be replaced.

**NOTE:** *There are three different ratings used. If replacing a fuse, ensure that the correct value is used.*

### Precautions if Using Generator Power

The power output from onsite generators can cause power spikes that may damage electrical components within the cabinet. When connecting to sites powered by generators, please take the following precautions:

1. Install a power conditioner. Although generators are fitted with power regulators, most are not filtered sufficiently for powering sensitive electrical components. We recommend installing a commercial power conditioner and/or UPS between the generator and the unit.
2. Before starting a generator, make sure the power to the unit is turned off. Start the generator, let the generator reach stable operating speed and wait 30 seconds before reconnecting the power to the unit.
3. For units where the generator starts and stops on demand, install a delay timer or PLC to automatically isolate the unit until the operating speed and consistent power output is achieved.
4. Isolate the unit before shutting down the generator.

## Error Messages

Error Code	Fault	Action
Err 3	No price or pump number set.	Set the pump number or: Set a price at the pump or at the controller.
Err 7	Excess flow.	Max Flowrate exceeded.
Err 8	Excess reverse rotation of encoder.	Check product is not flowing back into the tank once the delivery has finished.
Err 9	Faulty or disconnected meter encoder.	<ol style="list-style-type: none"> <li>1. Check that encoder is plugged in.</li> <li>2. Replace encoder PCB on meter.</li> </ol>
Err 10	Configuration Lost.	Reconfigure C4000. Refer to the C4000 master manual.
Err 12	C4000 memory failure.	Change memory IC. F-AD-DS1225 (not applicable to Futra.)
PEd Abd	Display error.	<ol style="list-style-type: none"> <li>1. Check display cable for loose wires/crimps.</li> <li>2. Replace display PCB.</li> </ol>